

# M63975FP

IGBT MOSFET DRIVER

## DESCRIPTION

M63975FP is Power MOSFET and IGBT module driver for half bridge applications.

## FEATURES

- SUPPLY VOLTAGE ..... 24V
- OUTPUT CURRENT ..... ±600mA
- LOW SIDE DRIVER
- SOP-10
- BUILT-IN SOFT STOP FACILITY

## APPLICATION

MOSFET and IGBT module inverter driver

## PIN CONFIGURATION (TOP VIEW)

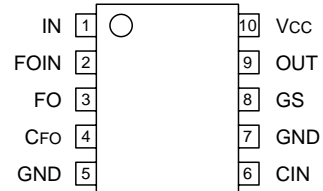

NC:NO INTERNAL CONNECTION

Outline 10P2N

## BLOCK DIAGRAM

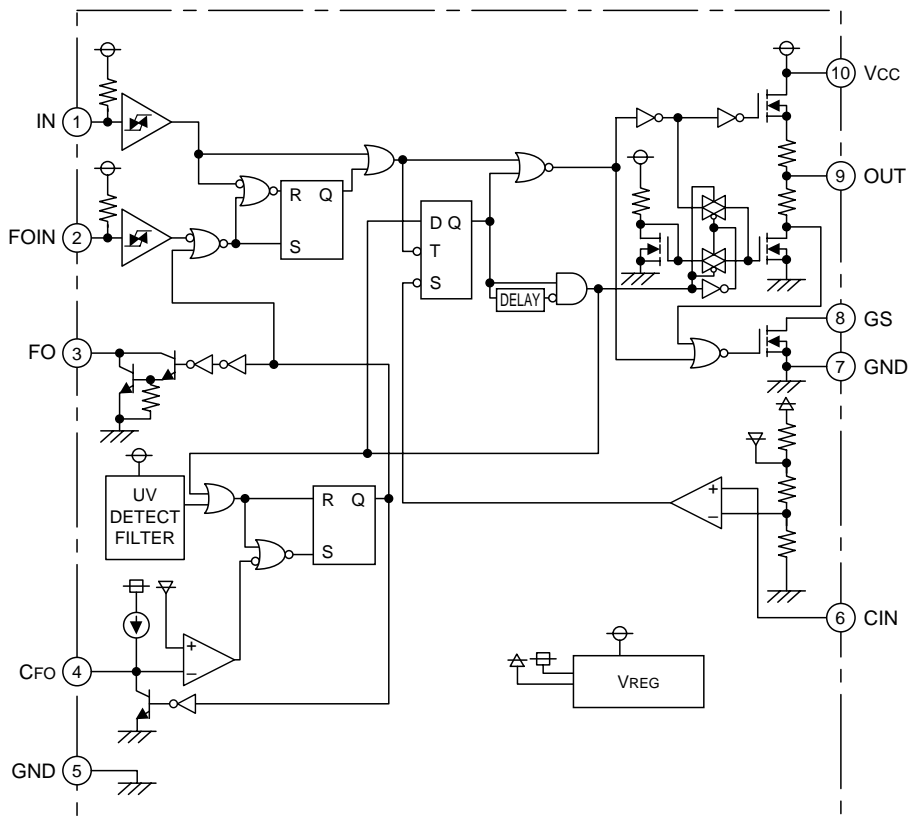

# M63975FP

## IGBT MOSFET DRIVER

### ABSOLUTE MAXIMUM RATINGS

Symbol	Parameter	Conditions	Ratings	Unit
VCC	Fixed Supply Voltage		-0.5 ~ 24	V
VOUT	Output Voltage 1		-0.5 ~ VCC+0.5	V
IOUT	Output Current 1		±600	mA
VGS	Output Voltage 2		-0.5 ~ VCC+0.5	V
IGS	Output Current 2		375	mA
VIN	Input Voltage		-0.5 ~ VCC+0.5	V
VFIN	FOIN Input Voltage		-0.5 ~ VCC+0.5	V
VCIN	CIN Input Voltage		-0.5 ~ VCC+0.5	V
VFO	FO Output Voltage		-0.5 ~ VCC+0.5	V
IFO	FO Output Current		15	mA
PD	Package Power Dissipation	Ta = 25°C, Non Board	0.43	W
Kθ	Linear Derating Factor	Ta > 25°C, Non Board	-4.31	mW/°C
Tj	Junction Temperature		-20 ~ 125	°C
Topr	Operation Temperature		-20 ~ 75	°C
Tstg	Storage Temperature		-40 ~ 125	°C

### RECOMMENDED OPERATING CONDITIONS

Symbol	Parameter	Test conditions	Limits			Unit
			Min.	Typ.	Max.	
VCC	Fixed Supply Voltage		13.5	—	16.5	V
VIN	Input Voltage		0	—	5	V

### THERMAL DERATING FACTOR CHARACTERISTIC

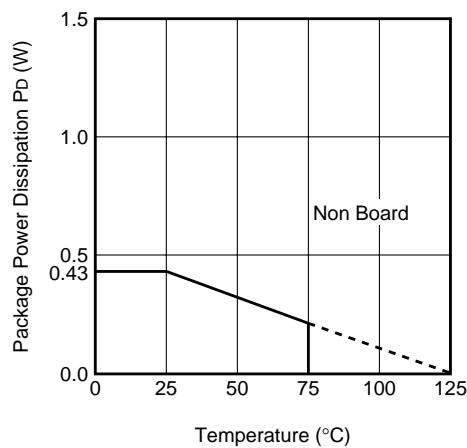

**ELECTRICAL CHARACTERISTICS (Ta=25°C, Vcc=15V, GND=0V unless otherwise specified)**

Symbol	Parameter	Test conditions	Limits			Unit
			Min.	Typ.*	Max.	
ICC	Vcc Standby Current	VIN=VCC	1.0	2.0	3.5	mA
VIH	High Level Input Threshold Voltage	VIL: Low Level Input Threshold Voltage	2.5	3.0	4.0	V
VINh	Input Hysteresis Voltage	VINh=VIH-VIL	0.5	1.6	3.2	V
IiH	High Level Input Bias Current	VIN=VCC	-0.1	—	—	μA
IiL	Low Level Input Bias Current	VIN=0V	50	100	200	μA
VCCuvr	Vcc Supply UV Reset Voltage	VCCuvt: Vcc Supply UV Trip Voltage	11.2	12.0	12.8	V
VCCuvh	Vcc Supply UV Hysteresis Voltage	VCCuvh=VCCuvr-VCCuvt	—	0.5	—	V
tVCCuv	Vcc Supply UV Filter Time		—	10.0	—	μs
VFIH	FOIN High Level Input Threshold Voltage	VFIL: Low Level Input Threshold Voltage	2.5	3.0	4.0	V
VFIh	FOIN Input Hysteresis Voltage	VFIh=VFIH-VFIL	0.5	1.6	3.2	V
IFIH	FOIN High Level Input Bias Current	VFIN=VCC	-0.1	—	—	μA
IFIL	FOIN Low Level Input Bias Current	VFIN=0V	50	100	200	μA
VCIN	CIN Input Threshold Voltage		0.40	0.50	0.60	V
tcIN	CIN Propagation Delay		—	0.5	0.8	μs
VCFH	CFO Threshold Voltage		2.6	3.0	3.4	V
ICFO	CFO Source Current	VcFO=0V	-40.0	-25.0	-15.0	μA
IFO	FO Leak Current	VFO=VCC	—	—	1.0	μA
VFO	FO Output Saturation Voltage	Ifo=15mA	0.7	1.2	2.0	V
VOH	High Level Output Voltage	Io=0mA	13.3	14.0	—	V
VOL	Low Level Output Voltage	Io=0mA	—	—	0.1	V
ROH	Output High Level On Resistance	Io=-200mA, ROH=(VOH-Vo)/Io	26.3	35.7	71.4	Ω
ROL	Output Low Level On Resistance	Io=200mA, ROH=Vo/Io	13.0	19.0	28	Ω
tdLH	Turn-On Propagation Delay	OUT-GND	—	300	900	ns
tdHL	Turn-Off Propagation Delay	OUT-GND	—	300	900	ns
VoTh	GSOUT Threshold Voltage		1.5	2.5	3.8	V
VGS	GS Output Saturation Voltage	IGS=100mA	0.7	1.6	2.5	V
ISO	OUT Soft Cut-Off Sink Current	VCIN=1V, Vo=VCC	—	20	—	mA
tSO	OUT Soft Cut-Off Delay		2.0	5.5	9.0	μs

\* Typ. is not specified.

**TIMING DIAGRAM**

1. SC

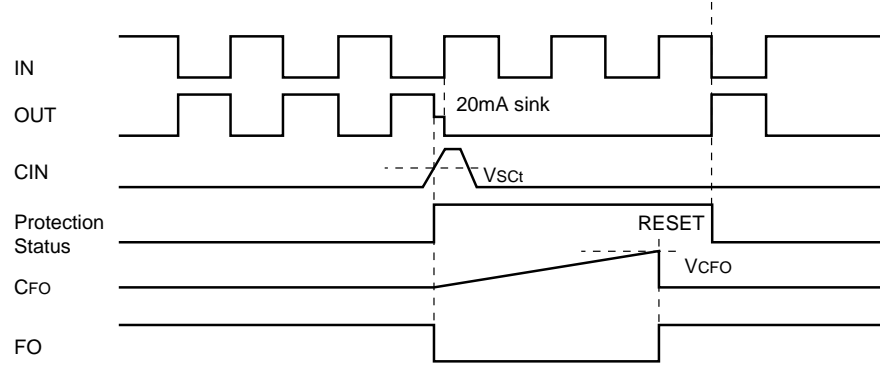

2. UV

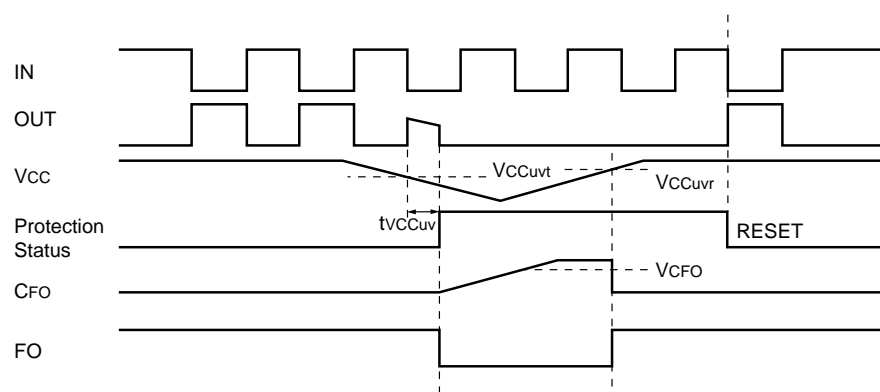

3. FOIN

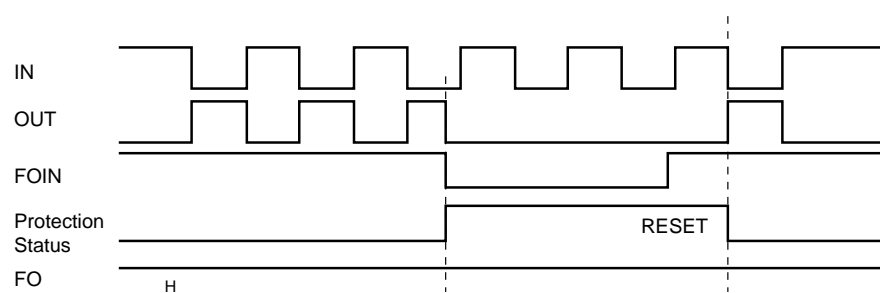

PACKAGE OUTLINE

**10P2N-A**

EIAJ Package Code	JEDEC Code	Weight(g)	Lead Material
SOP010-P-300-1.27	-	0.16	Cu Alloy

Plastic 10pin 300mil SOP

